

CORPORATION OF THE
TOWNSHIP OF BILLINGS

AGENDA

May 30th, 2022 7:00 p.m.

Electronic

1. OPEN
2. APPROVAL OF AGENDA
3. DISCLOSURE OF PECUNIARY INTEREST
4. ADOPTION OF MINUTES
5. DELEGATIONS
6. COMMITTEE REPORTS
7. OLD BUSINESS
8. NEW BUSINESS
 - a) 2022-27 Dock System at the Aus Hunt Marina
9. CORRESPONDENCE
10. INFORMATION
11. ACCOUNTS FOR PAYMENT
12. CLOSED SESSION
13. CONFIRMING BY-LAW
14. ADJOURNMENT

Memorandum

To: Mayor, Council
cc: Staff, Public
From: Staff
Date: May 26th, 2022
RE: **May 30th, 2022 Special Council Meeting**

4. Minutes

None.

5. Delegations

None.

6. Committee Reports

None.

7. Old Business

None.

8. New Business

a) 2022-27 Dock System at the Aus Hunt Marina

Recommendation:

That Council pass by-law 2022-27, being a By-Law to enter into a contract with Kropf Industrial for the supply and installation of a new floating dock structure along the sheet piling at the Aus Hunt Marina in response to RFQ process 2022-03.

Background:

- Replacing docks along the sheet piling wall at the AHM is part of a project initiated last year (2021), which included the new sheet piling along the West side of the AHM basin.
- This project was partially funded (75%) through the FedNor Tourism Relief Fund (TRF). Purchase and installation of the replacement docks represent the final component of this project.
- Billings RFQ 2022-03, an RFQ seeking the supply and installation of floating docks for this location, was issued in March of this year. It was targeted to seven (7) commercial dock suppliers.
 - Three (3) suppliers expressed willingness and ability to supply this year (2022) and attended site visits.
 - Two suppliers, Kropf industrial and Dock Kings (King Industrial) provided quotes, although Kropf Industrial was the only supplier that used the quote form. Kropf also voluntarily attended a 2nd site visit, which was necessitated by the need to further refine the specifications of the installation.
- In addition to dock suppliers being busy, there were challenges associated with clearing/finalizing this RFQ process. This included, but was not limited to the following realities:

- Ice out was a little later this year, and the Lake Huron level is down again significantly, so we were a little delayed in getting a good view of the situation.
- We also needed some further consideration and some creative thinking on what would work best in the space available. The re-consideration about what could/should be done at the location was undertaken after the release of the RFQ, and with input from both the former Treasurer (and person responsible for marina operation for years), Bruce Mercer, and the current Marina Manager, Jim Fowle. The AHM launch ramp was left in place, so we need to keep this launch site as functional as possible.
- It is important to note that the recommended quote exceeds the dock component budget of the project by approximately \$11,500. However, in the opinion of staff, the dock array as spec'd, laid out, and costed, represents a dockage situation on the sheet wall that equals what was there before in terms of # of slips, and significantly exceeds what was there in terms of quality - and it also improves the utility of the launch ramp. The system, as depicted and spec'd, should provide a robust and flexible solution for that portion of the Aus Hunt Marina.
- It is also important to note that the original costing on new docks as a component of the AHM sheet piling project was completed nearly a year ago. Given the cost inflation that has occurred during the past year, across the board, this cost over-run is worthy of consideration, especially since it allows for maximizing the utility of the marina space in this location.

Project Financials (Total AHM Sheet Piling Project):

Total costs budgeted under the FedNor Project:	\$352,502
Amount claimed to date:	\$282,848
Budget remaining:	\$69,654
Docks supplied and installed (this quote):	\$81,168
Budget overage	\$11,514

9. Correspondence

None.

**The Corporation of the
Township of Billings**

By-Law 2022-27

Being a By-Law to enter into a contract with Kropf Industries Inc. for the supply and installation of a new floating dock system along the sheet piling at the Aus Hunt Marina.

WHEREAS the Township of Billings issued RFQ #2022-03 seeking the supply and installation of a new floating dock system at the Aus Hunt Marina,

WHEREAS Kropf Industries Inc.'s response to RFQ #2022-03, their quote with a total upset cost of \$81,167.90 including HST, was deemed the successful bid upon review of all submitted proposals;

NOW THEREFORE the Corporation of the Township of Billings enacts as follows:

1. That the Mayor and CAO/Clerk are hereby authorized to execute the contract attached hereto as Schedule A; and,
2. That this by-law shall come into force and take effect on the date of its passing.

Read a First, Second and Third time and enacted this 30th day of May, 2022.

Ian Anderson, Mayor

Kathy McDonald, CAO/Clerk

APPENDIX A: QUOTE FORM

PROPOSAL C LAYOUT

RFQ Number: 2022-03

The Corporation of The Township of Billings, Request for Quote for Supply and Install New Floating Dock & Ramp System.

Note: Failure to provide the complete Form of Quote, submitted as an original document, complete with original authorized signature(s), at time of Quote closing, will result in the Quote submission being disqualified and not considered for award. Copies of this schedule shall be included in all copies of Quotes prepared for The Township.

The Supplier has carefully examined the conditions and specifications attached and referred to in this contract and has examined the site and work locations and understands and accepts the said conditions and specifications, and for the prices set forth in this tender, hereby offers to furnish all labour, equipment, and materials, except as otherwise specified in the contract, to complete the work in strict accordance with said conditions and specifications.

Suppliers must complete this form and include with the quotation submission. Please ensure all information is legible:

Notes

1. I/We hereby submit the attached quotation documents to satisfy the requirements as described in this RFQ issued by The Township.
2. I/We agree that we have reviewed and understood the quotation documents and I/We are capable and qualified to perform the requirements of the contract and enter into a legal agreement with The Township in regard thereto and where the quotation is submitted by a corporation, it shall be signed and duly authorized officer of the company. Should the quotation be submitted by a partnership or proprietor, it shall be signed by the partners or owner.
3. It is also agreed that, upon acceptance in writing by The Township, the quotation documents need to be signed by The Township and become the "Agreement for the performance of the work" between the Contractor and The Township.
4. I/We agree that this offer shall be irrevocable from the time the quotations are opened and for a period of 90 calendar days.
5. I/We (the Supplier) promise to perform the work without undue delay and complete the project by September 30th, 2022.
6. The Supplier offers to provide the services detailed within the quotation package to the acceptance of The Township for the following upset cost limit.

Contact Information

Company Name: Kropf Industrial Inc.
Contact Individual: Jordan Kropf
Office Phone #: 705-378-2453
Cellular Phone #: 705-346-1586
Fax #: 705-378-5068
E-Mail Address: jordan@kropfindustrial.com

Postal Address:

Street # or PO Box #	1
Street Name	1 Quebec Dr
Community	Seguin, ON
Postal Code	P2A 0B2

Cost Quote

PROPOSAL C LAYOUT

Component	Cost
Floating Dock System, Installed	\$69,310.00
Ramp System, Installed	\$2,520.00
Total Upset Cost (Exclusive of HST)	\$71,830.00
HST	\$9,337.90
Total Upset Cost	\$81,167.90

Payment Procedures

The Township is willing to discuss the payment process expectations with the chosen supplier.

QUOTATION SUBMITTED BY:

The undersigned affirms that he/she is duly authorized to execute this bid and that all costs associated with this quotation have been submitted.

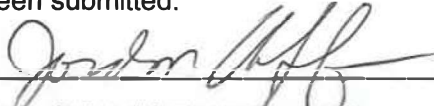
BIDDER'S SIGNATURE AND SEAL: 

NAME AND POSITION: Jordan Kroft - Sales Manager

WITNESS SIGNATURE: 

WITNESS NAME AND POSITION: Tim Gingrich - Controller

(If Corporate Seal is not available, documentation should be witnessed)

DATED AT Seguin, ON

THIS 20 DAY OF May, 2022

APPENDIX B: IRREVOCABLE OFFER

Form of Irrevocable Offer

The signing of this quotation for and on behalf of The Township shall constitute a binding contract between The Township and the Supplier signing below.

Schedule

The approximate schedule for this project would be as follows:

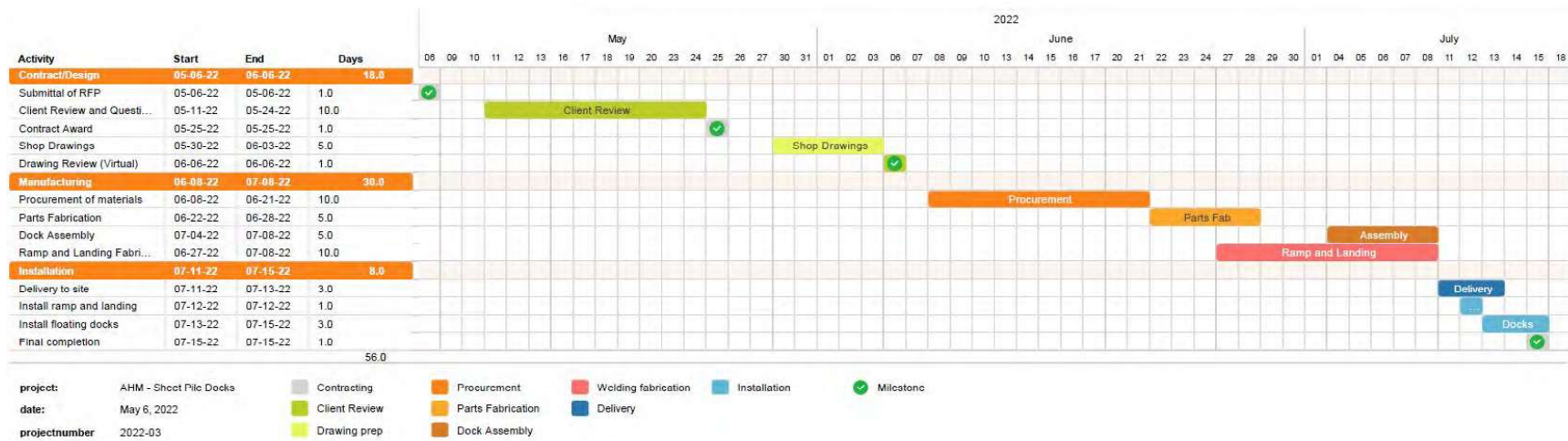

Based on a contract award date of May 25, 2022, we are estimating project completion and the docks ready for service by July 15, 2022.

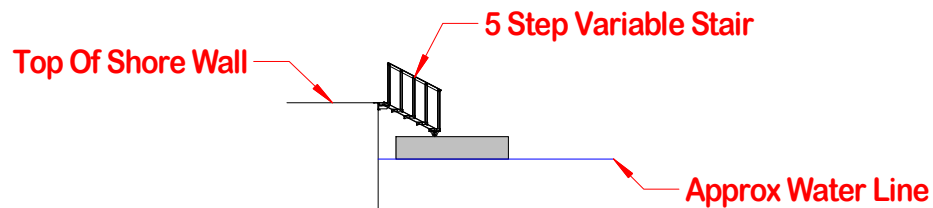
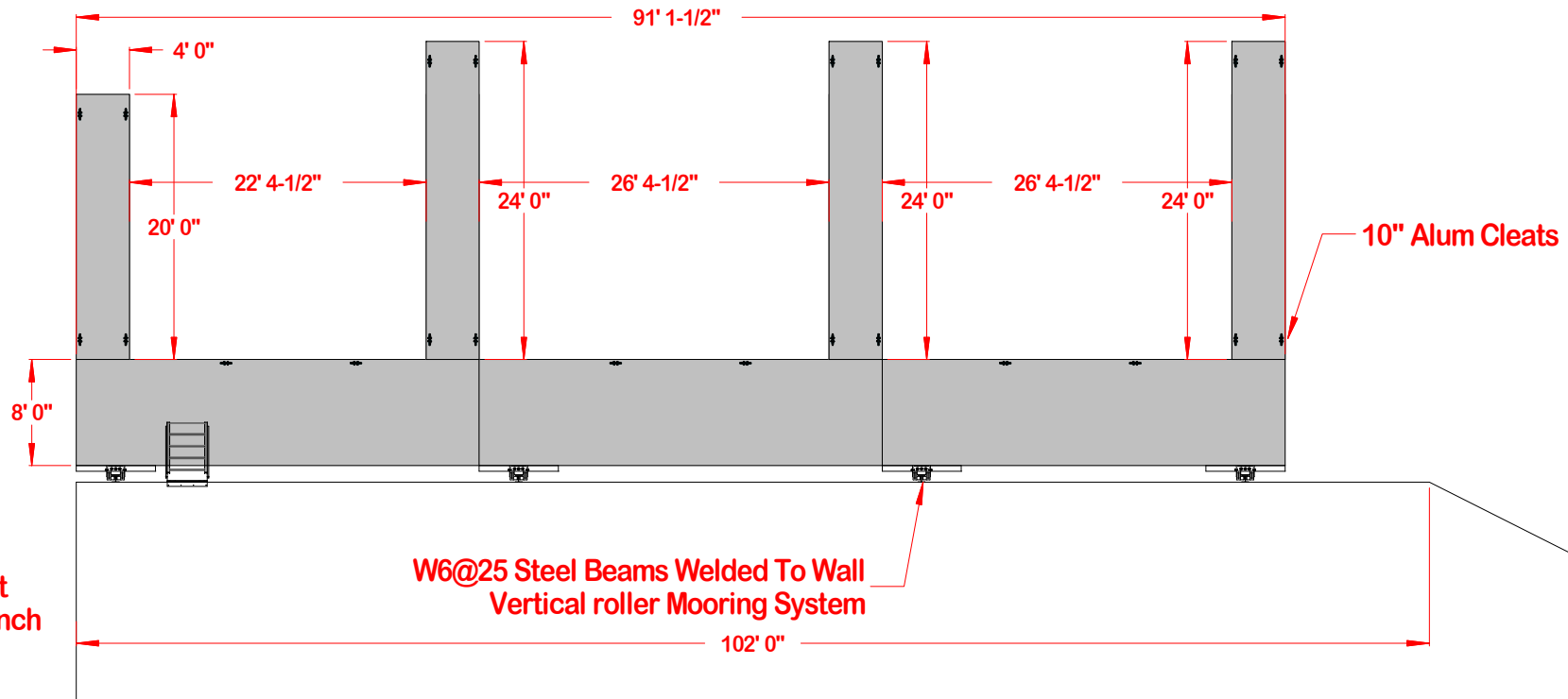

HDPE Docks

NOTES:
 1. WELDING:
 STEEL - CSA W47.1
 ALUMINUM - CSA W47.2
 UNLESS OTHERWISE SHOWN, WELD SIZE SHALL BE EQUIVALENT TO THICKNESS OF MEMBERS BEING JOINED.
 2. ALL ALUMINUM STRUCTURAL MEMBERS ARE 6061-T6
 ALL STEEL STRUCTURAL MEMBERS ARE 4W
 3. UNLESS OTHERWISE SPECIFIED BOM IS STEEL
 4. SPECIFIED LOADS.

ENGINEER'S SEAL

NOTES

A	TITLE
B C	SCALE:
A	DETAIL NUMBER
B	SHEET NUMBER - WHERE DETAIL REQUIRED
C	SHEET NUMBER - WHERE DETAIL LOCATED

File Name Proposal C May 20-22	DRAWING Proposed Dock Layout Option "C"
Location Kagawong AHM	DATE May 20-2022
CUSTOMER Kagawong Municipality Of Billings	DRAWN BY MS



THIS DRAWING IS THE PROPERTY OF KROPP INDUSTRIAL INC AND IS NOT TO BE COPIED OR REPRODUCED WITHOUT WRITTEN PERMISSION

JOB NUMBER
SHEET NUMBER